

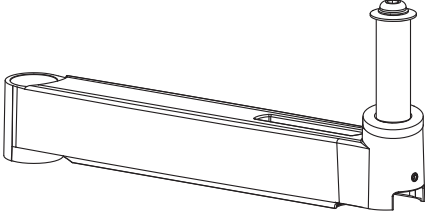

Assembly & Installation Instructions: Conform Accessory Flat Extension Arm CONF-ACC-1EXT-S

Parts Included

A Conform Flat Extension Arm
Qty: 1



B Pivot Cover Cap
Qty: 1



D 2 mm Spacer
Qty: 1



C Hook & Loop Strips
Qty: 2



Required Parts Sold Separately

Selected Pole Mount option with mounting hardware
Selected Conform Static Arms.

Tools Required

A Phillips head screwdriver, 2.5 mm Allen Wrench,
5 mm Allen Wrench



Do not use on hollow core tables.
Do not rotate or suspend arm beyond table surface.
If 3 arms are mounted in series, the maximum monitor weight in the entire system must not exceed 27 lb.
Do not link more than 3 arms in series.

NOTE: Extension cables for monitor power and video may be required.

1 Remove one arm.

- a** Loosen the set screw with a 2.5 mm Allen Wrench (included with base).
- b** Remove the Pivot Cover Cap, then remove the Bolt and Washer, using a 5 mm Allen Wrench (included with base). Set aside Bolt and Washer for use in Step 2f.
- c** Pull out the arm from the pin.
- d** Remove & discard the 4 mm spacer (Articulating Arm only).
- e** Insert 2 mm Spacer (D) (Articulating Arm only).

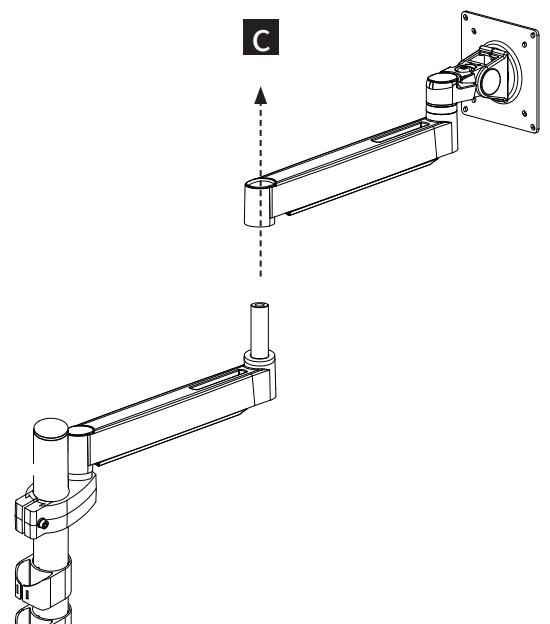
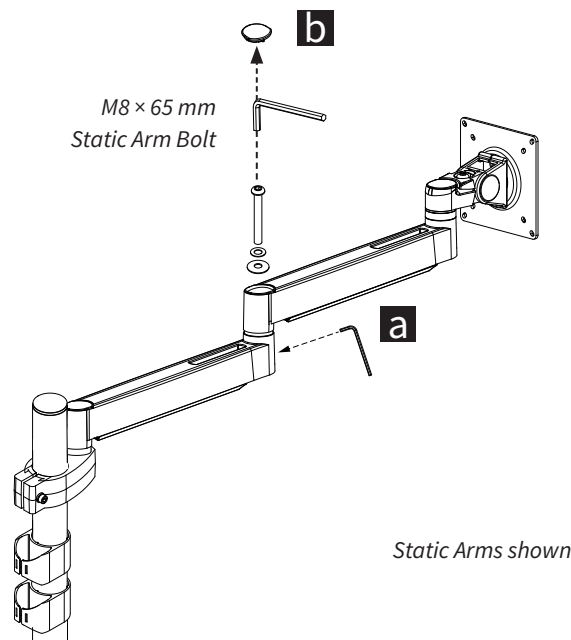
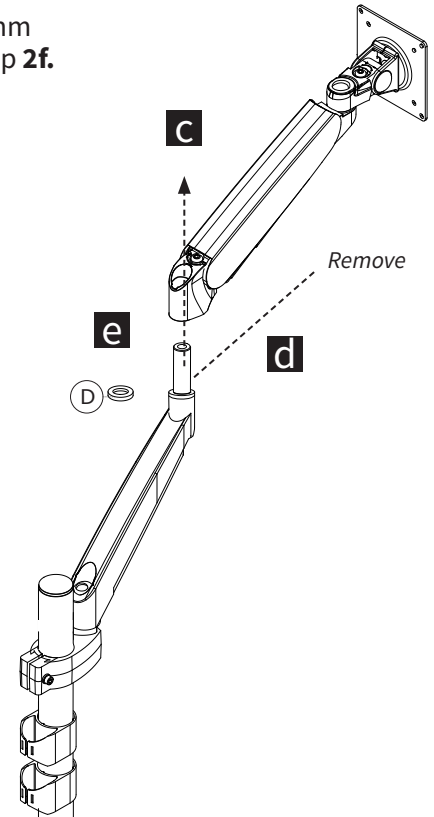
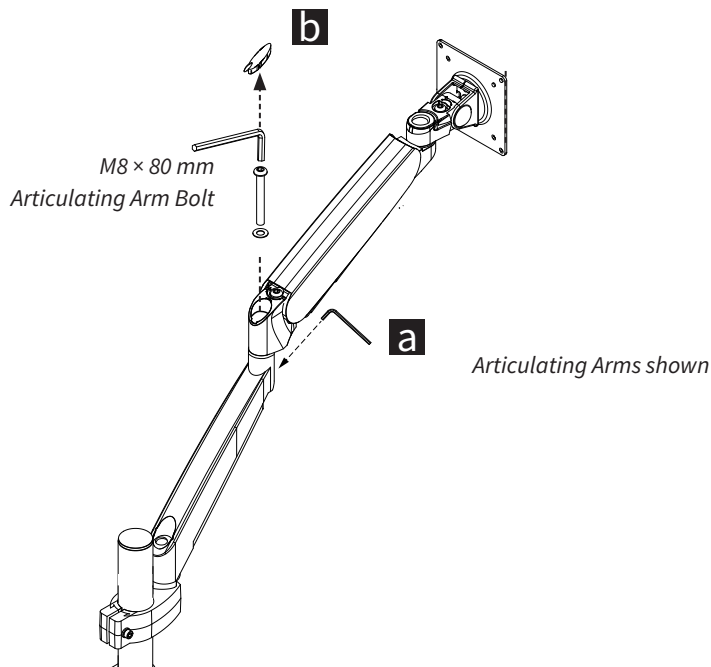

2 Attach the Flat Extension Arm.

- a** Remove M8 x 65 mm Bolt and Washers from Flat Extension Arm (A) as shown.
- b** Place the Flat Extension Arm (A) on Pin, resting on spacer.
- c** Assemble the Bolt and Washers as shown. For the Articulating Arm, use the M8 x 65 mm Bolt from the Flat Extension Arm (A).
- d** Tighten with a 5 mm Allen Wrench (included with base). Be sure the arm is tight but rotates freely. Snap on the Pivot Cover Cap B).
- e** Tighten the installed set screw with a 2.5 mm Allen Wrench (included with base).

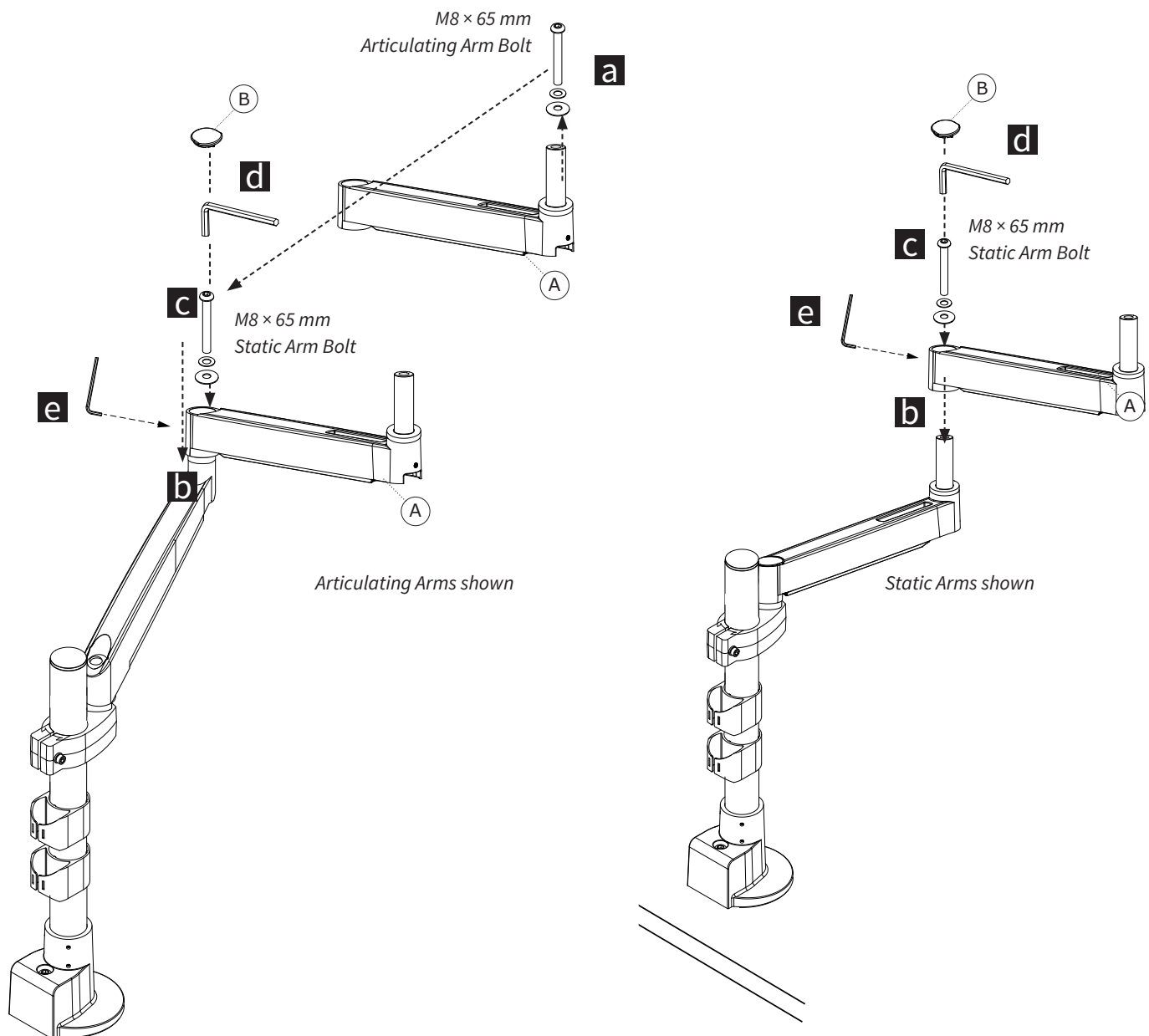

2 Attach the Flat Extension Arm continued.

- f** Place the Arm on Pin. Assemble the Bolt and Washers as shown. Tighten with 5 mm Allen Wrench (included with base). Be sure the arm is tight but rotates freely. Snap on the Pivot Cover Cap. Tighten the installed set screw with a 2.5 mm Allen Wrench (included with base).

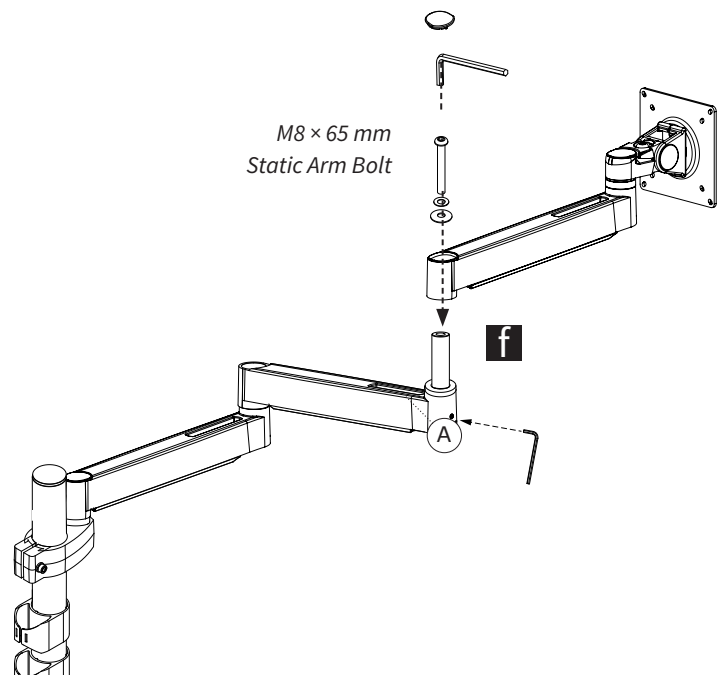
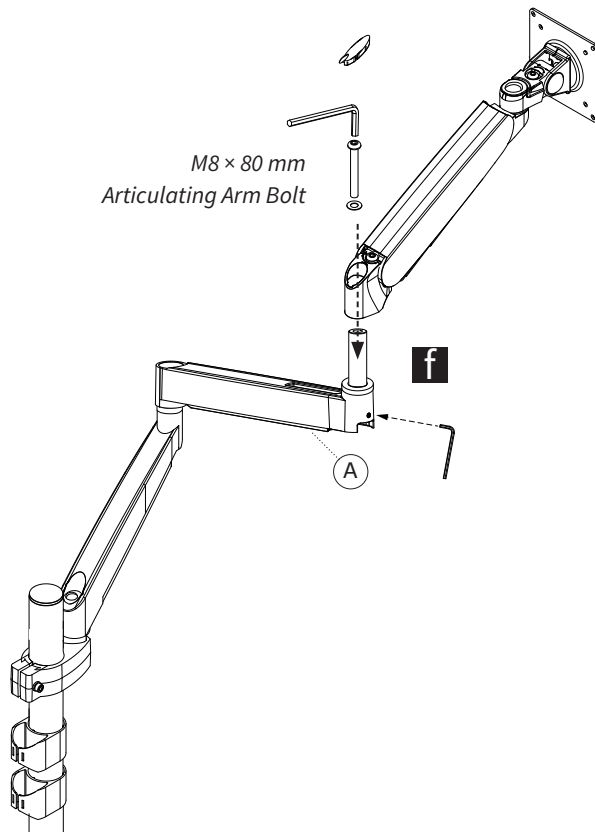

! If 3 arms are mounted in series, the maximum monitor weight in the entire system must not exceed 27 lb. Do not link more than 3 arms in series.